

# federal package®

## 720 and 780 Containers

### Propel/Repel

Federal Package offers the following decorating processes for these containers:

- Extended copy labeling available for new FDA sunscreen label
- Multicolor Fed-Flex® label
- 2-Panel (front/back) or full wrap

### 720 Container Specifications

Height: 2.41"

Diameter: 1.50 x .75"

Capacity: .35 oz.

Material: Polypropylene/HDPE

Colors: All three components are available in white, black, natural and custom colors

### 780 Container Specifications

Height: 2.76"

Diameter: 1.50 x .75"

Capacity: .50 oz.

Material: Polypropylene/HDPE

Colors: All three components are available in white, black, natural and custom colors

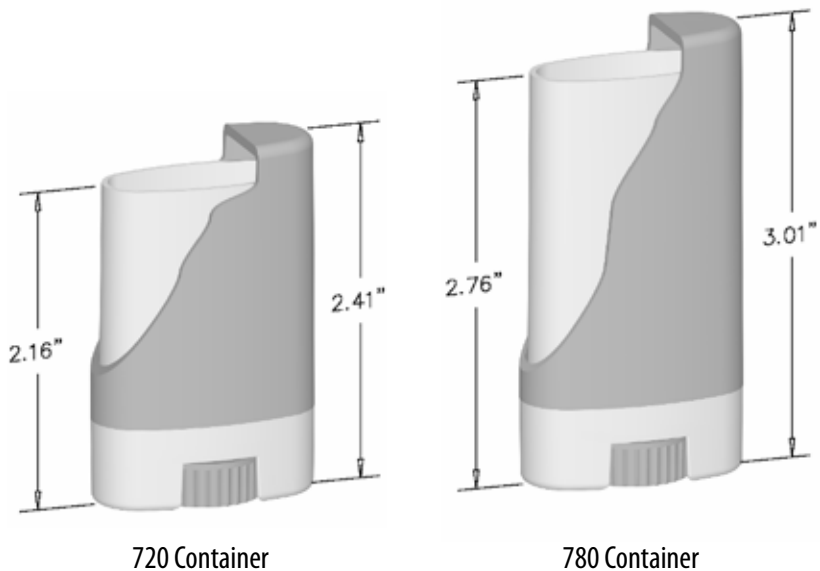

**ECO SMART®**

Earth friendly plastic that returns to nature®

Eco Smart containers by Federal Package are the ideal solution to meet your sustainability goals. This proprietary technology enables plastic components to break down in biologically active environments. The Eco Smart brand by Federal Package is a direct upgrade to our existing line of world class products with no change in form, fit, or function.

### Additional Capabilities

Federal Package is FDA registered and offers a full range of small container solutions that allow us to deliver a complete turnkey product for you:

- **Compounding & Filling:** We offer contract manufacturing services and can fill almost any lip balm or sunscreen product as well as many other types of containers
- **Decorating & Labeling:** We can work with you to create a specialty container look to help you stand out in the market
- **Blister Carding & Retail-Ready Packaging:** We can easily provide a retail-ready package for lip balm containers, sunscreen containers and much more, per your exact specifications

## Federal Package

8100 Powers Blvd, Chanhassen, MN 55317-8105

952.658.7593 • [www.federalpackage.com](http://www.federalpackage.com)

FDA Registered • Made in the USA